

**Jackson Township Road Department**  
**DRIVEWAY & YARD PIPE PROGRAM WORK REQUEST FORM**  
**CALL FOR INSPECTION 24 HRS PRIOR**  
**SHANE FARNSWORTH 614-991-6881**

Applicant: \_\_\_\_\_

Property Location / Address: \_\_\_\_\_

Parcel No#. \_\_\_\_\_ Phone / Contact#: \_\_\_\_\_

Description of Work Requested: \_\_\_\_\_

\_\_\_\_\_

\_\_\_\_\_

**Specific Permit Information**

\_\_\_\_ Sidewalk      \_\_\_\_ Approach      \_\_\_\_ Repair / Replace      \_\_\_\_ Alter Existing

**Submittal Requirements**

Site Plan indicating existing sidewalks/approaches and any proposed changes.

**Concrete approach must be 6" thick with maximum allowable slope of 10%.**

**Concrete must be 4" thick for sidewalk with a maximum allowable slope of 2%.**

*By my signature below, I have read and understand the Pipe Policy and agree that the cost of all materials (including pipe, top soil, fill dirt, gravel, bedding materials, and backfill materials) and the delivery cost of the same to the job site is my responsibility as the property owner. I also understand and agree that final grading and seeding of grass is my total responsibility and cost.*

\_\_\_\_\_  
*Signature of Property Owner*

\_\_\_\_\_  
*Date*

**TOWNSHIP ACTION & COSTS**

Received by Road Department (Date): \_\_\_\_\_

Work Scheduled for (Date): \_\_\_\_\_

Work Finished on (Date): \_\_\_\_\_

**COST REVIEW**

Item	Quantity	Estimated	Actual	Comments
Pipe N-12, Concrete				
Backfill Dirt / Gravel				
Connectors / Fittings				
Other Items				
<b>TOTALS</b>				

# DRIVEWAY & YARD PIPE PROGRAM

Jackson Township Road Department 614-565-6148

## Intent

It is the intent of this Policy to provide consistent and current specifications for the installation of stormwater and drainage pipe only for those properties and locations within the public rights-of-way for roadways under the jurisdiction of Jackson Township.<sup>i</sup> This Policy is intended to improve or correct drainage problems with collateral benefits of improving private property and making the public rights-of-way safer, easier to maintain and more aesthetically appealing.

## General Pipe Criteria

Driveway and Yard pipe installation shall generally follow ODOT Specifications as listed in the “Construction and Material Specifications Handbook” allowing exceptions for variance from minimum coverage due to local situations. Property owners shall purchase all pipe and material and have those items delivered to the job site. Upon completion and approval by the Trustees of the Work Request Form, Jackson Township shall install 12” (twelve-inch) diameter\* driveway and yard section of pipe without charge and will maintain these pipes until replacement becomes necessary.

*\*Note: Property owners will assume all costs for materials up to and including 12” diameter yard pipe. When a pipe larger than 12” diameter is required, the Jackson Township Road Department will be responsible for the difference in costs between that larger pipe and the 12” diameter pipe.<sup>ii</sup>*

ODOT Specifications, Sect. 603			
Pipe Type	Description and Use	Bedding 603.04	Backfill 603.08
Type B	Storm Drains, under pavement	6” granular	12” granular
Type C	Storm Drains, in R-O-W	Ex. Dirt	Varies, 3” minimum cover
Type D	Pipe under Driveways / Approach	Ex. Dirt	Varies, 3” minimum cover
Type E	misc. yard drainage pipes	Ex. Dirt	Suitable soils to cover

### Notes:

1. Minimum pipe shall be 12” diameter N-12 polyethylene, smooth lined corrugated pipe.
2. Pipe will be hydraulically sized and flow line determined by Jackson Township Foreman.

## Driveway Pipe

A Driveway Pipe is designed to carry water from one side of the drive to the other, bear the weight of the driveway above it, and carry the weight of traffic loads driving over it. Minimum length for all driveways is 24’ (twenty-four feet).

1. Quantity / Length of pipe materials is determined by the following formula. Width + plus 4’ (four-feet) + plus 4\*times (6\*times is desirable) the vertical distance from established flow line to drive profile.  
*Example: a 4’ ditch requires a minimum of 30’ (thirty-feet) of pipe (however, 38’ is more desirable).*
2. Headwalls are NOT permitted.
3. All driveway pipe shall be jointed and sealed by Jackson Township
4. Acceptable materials shall be **REINFORCED CONCRETE**<sup>iii</sup> (if adequate trench width and cover is available) or N-12 polyethylene, smooth lined corrugated pipe **ONLY** when backfilled with a minimum depth of (12”) twelve-inch granular backfill materials.<sup>iv</sup>

## **Yard Pipe**

A yard section pipe is designed to carry water from one side of the property to the other in the roadside ditch.

1. Yard section pipe shall be jointed and open (unsealed)
2. An inlet or catch basin shall be placed on the upstream side of the drive with a 12" opening.
3. Acceptable material shall be Reinforced Concrete, Non-reinforced concrete, and N-12 Polyethylene double wall Smooth Corrugated Pipe.

## **Payment**

1. Property Owner is responsible for the payment of all materials including pipe, pipe connectors, catch basins, grates, backfill materials, gravel, dirt, etc.
2. Depending on the size and cost of the project, the Township may provide the property owner with a Monthly or Quarterly payment plan option, with the first payment due upon completion and the balance billed monthly or quarterly as pre-arranged with the property owner.
3. In some cases, the Jackson Township Road Department may be able to arrange pick-up and delivery of drainage pipes and connectors directly from the vendor when convenient to, and in the interest of, the Township Road Department (i.e., when an oversized diameter pipe may be needed or when timing of project coincides with other Township drainage projects). In these situations, the property owner is required to pre-pay to the vendor the full costs of the materials (delivery charges can be waived).
4. In some cases, the Jackson Township Road Department may be able to provide the backfill materials directly to the project from sources or stockpiles on-hand or available in the immediate area with only a nominal hauling charge passed on to the property owner.
5. All checks shall be made payable to "Jackson Township Fiscal Officer."
6. Any property owner failing to provide payment as agreed upon, and after proper notices, will have the amounts past due placed as a property tax lien against the real estate.

## **STANDARD ILLUSTRATION OF PIPE PROFILES**

**NOTE DRAWING BELOW FOR SECTION WITH YARD PIPE:**

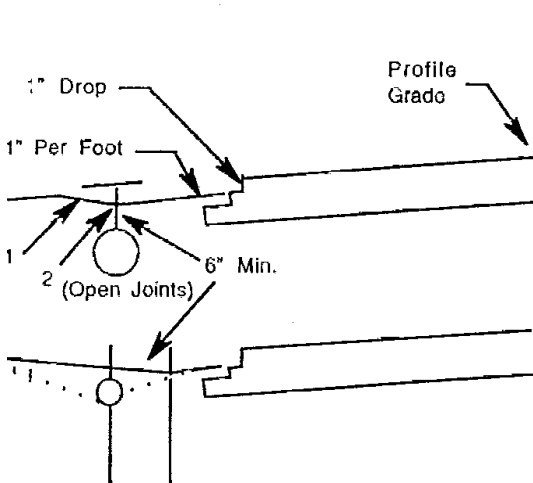

1. CUT SECTION 5' AND UNDER AT 3:1  
CUT SECTION OVER 5' AT 2 1/2:1
2. SWALE IN CUT SECTION IS TO BE MAINTAINED AT ALL TIMES.

<sup>i</sup> Resolution #90-105  
<sup>ii</sup> Resolution #98-110  
<sup>iii</sup> Resolution #96-160  
<sup>iv</sup> Resolution #02-44

**AFFIDAVIT**  
**DRIVEWAY & APPROACH APRON**  
**OFFICE OF THE JACKSON TOWNSHIP ZONING DEPARTMENT**  
**P. O. BOX 517**  
**GROVE CITY, OH 43123**

STATE OF OHIO                    )  
COUNTY OF FRANKLIN        ) ss

(Name) \_\_\_\_\_ being first duly cautioned and sworn, according to law deposes that he/she plans to construct / re-construct a **DRIVEWAY / DRIVEWAY APPROACH APRON** in a manner and style as described on the attached Certificate of Zoning Compliance for the property located at \_\_\_\_\_ (address).

\_\_\_\_\_ **Driveway.** Affiant states he/she will construct a driveway with approach on the property and that such driveway shall be in conformity with the regulations of the applicable Sections of the Jackson Township Zoning Resolution (as more fully described on the reverse of this Affidavit). Specifically, that the driveway will be a minimum of 10' feet off the lot line, a minimum of 10' feet wide, and a minimum of 18' feet wide at the street and be constructed of Concrete, Asphalt, Blacktop or Brick to be a "Durable and Dustless surface." The stone base for the driveway will be installed prior to the beginning of any construction activity. Affiant states and acknowledges that any areas of public rights-of-way disturbed or damaged during installation of the driveway/approach shall be restored to original or better condition meeting the approval of the Township Road Department.

*"Affiant further states and acknowledges that he/she has determined the exact location of the property lot lines and that such driveway and approach apron will not encroach upon the lot lines of adjoining properties, parcels of land or easements. Affiant states that he/she understands it is their duty to determine the exact location of their lot lines and easements."*

Affiant:

\_\_\_\_\_ (signature)

Sworn to before me and signed in my presence this \_\_\_\_\_ day of \_\_\_\_\_ 20\_\_\_\_\_

\_\_\_\_\_  
Notary

(Seal)