

# Jackson Township Road Department

## DRIVEWAY & YARD PIPE PROGRAM

### WORK REQUEST FORM

*I hereby request the Jackson Township Road Department to assist with the following corrective tiling actions for proper stormwater and drainage flow on the property listed below.*

Applicant: \_\_\_\_\_

Property Location / Address: \_\_\_\_\_

Lot No#. \_\_\_\_\_ Phone / Contact#: \_\_\_\_\_

Description of Work Requested: \_\_\_\_\_

\_\_\_\_\_

\_\_\_\_\_

*By my signature below, I have read and understand the Pipe Policy and agree that the cost of all materials (including pipe, top soil, fill dirt, gravel, bedding materials, and backfill materials) and the delivery cost of the same to the job site is my responsibility as the property owner. I also understand and agree that final grading and seeding of grass is my total responsibility and cost. I understand this Request will be submitted to the Jackson Township Board of Trustees for their review and approval and that all work will be completed by the Jackson Township Road Department as time allows, as determined by the Road Superintendent.*

\_\_\_\_\_  
*Signature of Property Owner*

\_\_\_\_\_  
*Date*

### TOWNSHIP ACTION & COSTS

Received by Road Department (Date): \_\_\_\_\_

Trustee Review (Date): \_\_\_\_\_ Comments: \_\_\_\_\_

\_\_\_\_\_

\_\_\_\_\_

Work Scheduled for (Date): \_\_\_\_\_

Work Finished on (Date): \_\_\_\_\_

#### COST REVIEW

Item	Quantity	Estimated	Actual	Comments
Pipe N-12, Concrete				
Backfill Dirt / Gravel				
Connectors / Fittings				
Other Items				
<b>TOTALS</b>				

Paid in Advance?    **Yes**  **No**

Billed For Work?    **Yes**  **No**

# DRIVEWAY & YARD PIPE PROGRAM

Jackson Township Road Department 871-1119

## Intent

It is the intent of this Policy to provide consistent and current specifications for the installation of stormwater and drainage pipe only for those properties and locations within the public rights-of-way for roadways under the jurisdiction of Jackson Township.<sup>i</sup> This Policy is intended to improve or correct drainage problems with collateral benefits of improving private property and making the public rights-of-way safer, easier to maintain and more aesthetically appealing.

## General Pipe Criteria

Driveway and Yard pipe installation shall generally follow ODOT Specifications as listed in the “Construction and Material Specifications Handbook” allowing exceptions for variance from minimum coverage due to local situations. Property owners shall purchase all pipe and material and have those items delivered to the job site. Upon completion and approval by the Trustees of the Work Request Form, Jackson Township shall install 12” (twelve-inch) diameter\* driveway and yard section of pipe without charge and will maintain these pipes until replacement becomes necessary.

*\*Note: Property owners will assume all costs for materials up to and including 12” diameter yard pipe. When a pipe larger than 12” diameter is required, the Jackson Township Road Department will be responsible for the difference in costs between that larger pipe and the 12” diameter pipe.<sup>ii</sup>*

ODOT Specifications, Sect. 603			
Pipe Type	Description and Use	Bedding 603.04	Backfill 603.08
Type B	Storm Drains, under pavement	6” granular	12” granular
Type C	Storm Drains, in R-O-W	Ex. Dirt	Varies, 3” minimum cover
Type D	Pipe under Driveways / Approach	Ex. Dirt	Varies, 3” minimum cover
Type E	misc. yard drainage pipes	Ex. Dirt	Suitable soils to cover

### Notes:

1. Minimum pipe shall be 12” diameter N-12 polyethylene, smooth lined corrugated pipe.
2. Pipe will be hydraulically sized and flow line determined by Jackson Township Foreman.

## Driveway Pipe

A Driveway Pipe is designed to carry water from one side of the drive to the other, bear the weight of the driveway above it, and carry the weight of traffic loads driving over it. Minimum length for all driveways is 24’ (twenty-four feet).

1. Quantity / Length of pipe materials is determined by the following formula. width + plus 4’ (four-feet) + plus 4\*times (6\*times is desirable) the vertical distance from established flow line to drive profile.  
*Example: a 4’ ditch requires a minimum of 30’ (thirty-feet) of pipe (however, 38’ is more desirable).*
2. Headwalls are NOT permitted.
3. All driveway pipe shall be jointed and sealed by Jackson Township
4. Acceptable materials shall be **REINFORCED CONCRETE**<sup>iii</sup> (if adequate trench width and cover is available) or N-12 polyethylene, smooth lined corrugated pipe **ONLY** when backfilled with a minimum depth of (12”)twelve-inches granular backfill materials.<sup>iv</sup>

## **Yard Pipe**

A yard section pipe is designed to carry water from one side of the property to the other in the roadside ditch.

1. Yard section pipe shall be jointed and open (unsealed)
2. An inlet or catch basin shall be placed on the upstream side of the drive with a 12" opening.
3. Acceptable material shall be Reinforced Concrete, Non-reinforced concrete, and N-12 Polyethylene double wall Smooth Corrugated Pipe.

## **Payment**

1. Property Owner is responsible for the payment of all materials including pipe, pipe connectors, catch basins, grates, backfill materials, gravel, dirt, etc.
2. Depending on the size and cost of the project, the Township may provide the property owner with a Monthly or Quarterly payment plan option, with the first payment due upon completion and the balance billed monthly or quarterly as pre-arranged with the property owner.
3. In some cases, the Jackson Township Road Department may be able to arrange pick-up and delivery of drainage pipes and connectors directly from the vendor when convenient to, and in the interest of, the Township Road Department (i.e., when an oversized diameter pipe may be needed or when timing of project coincides with other Township drainage projects). In these situations, the property owner is required to pre-pay to the vendor the full costs of the materials (delivery charges can be waived).
4. In some cases, the Jackson Township Road Department may be able to provide the backfill materials directly to the project from sources or stockpiles on-hand or available in the immediate area with only a nominal hauling charge passed on to the property owner.
5. All checks shall be made payable to "Jackson Township Fiscal Officer."
6. Any property owner failing to provide payment as agreed upon, and after proper notices, will have the amounts past due placed as a property tax lien against the real estate.

## **STANDARD ILLUSTRATION OF PIPE PROFILES**

**NOTE DRAWING BELOW FOR SECTION WITH YARD PIPE:**

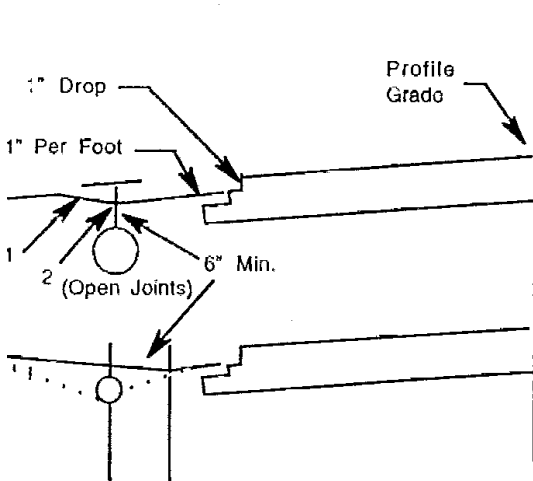

1. CUT SECTION 5' AND UNDER AT 3:1  
CUT SECTION OVER 5' AT 2 1/2:1
2. SWALE IN CUT SECTION IS TO BE  
MAINTAINED AT ALL TIMES.

<sup>i</sup> Resolution #90-105

<sup>ii</sup> Resolution #98-110

<sup>iii</sup> Resolution #96-160

<sup>iv</sup> Resolution #02-44